

# Cam Lock PRO

REPLACEMENT CAM LOCK INSTRUCTIONS



**1" TEST BOX**

Measure the "TEST BOX" to determine if this guide is printed correctly. All illustrations are actual size.

## Step 1 LOCKS

**Determine what size lock you need.** Place your current lock on the lock illustrations below for correct lock size. If your lock is a different size, please call us for further assistance.

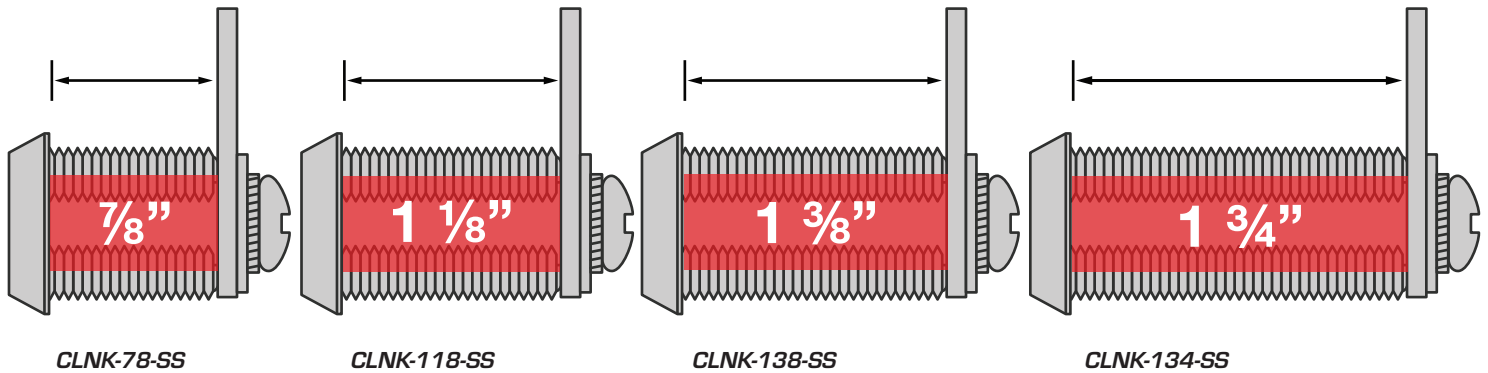

## Step 2 CAMS (Best practice is to reuse your existing cam.)

**Determine what size cam (locking arm) you need.** Place your current cam on the cam illustrations below for correct cam size. You can also measure manually using a ruler and measuring from the center hole of your cam to the longest end.

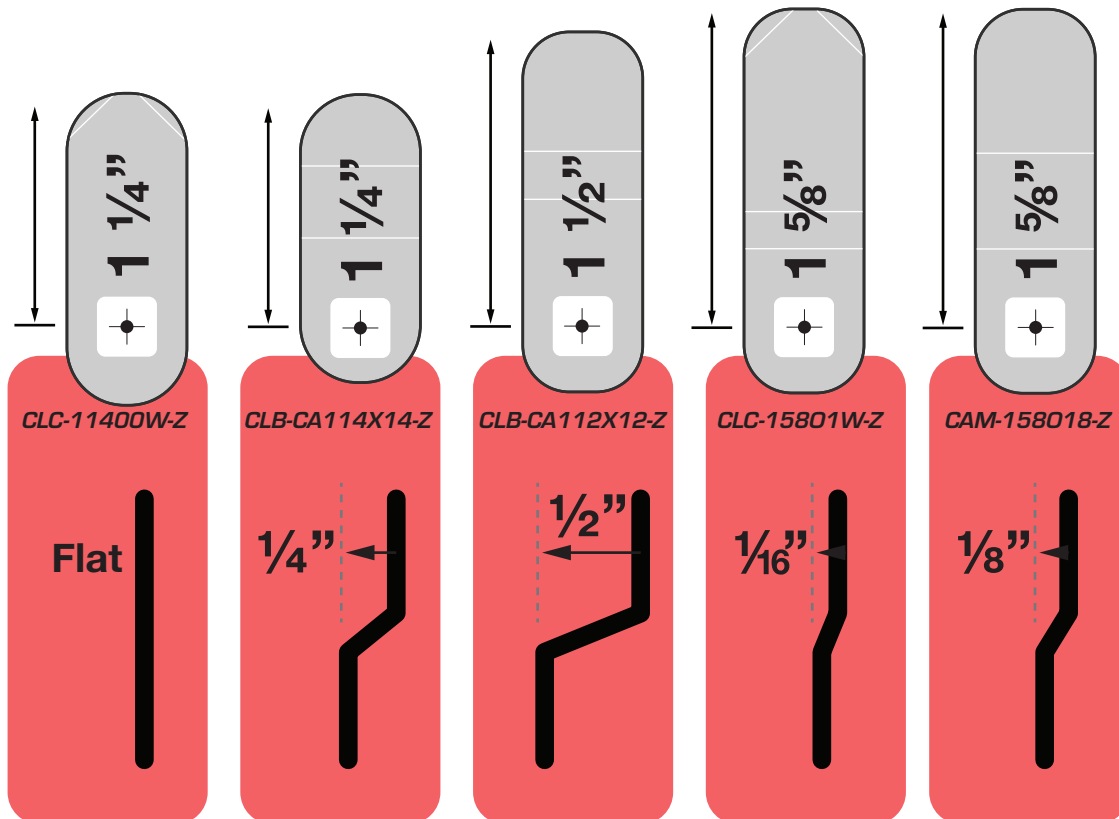

**BENDS**  
Each cam option shown has a specific offset (bend) as illustrated below. If you have a bend that is larger than 1/2", please call 888-400-3044 for further assistance.