



## Ultra E Lock User Instructions

The Global Link Ultra E Lock features:

- Convenient handle design, available in both right- and left-handed models
- Illuminated keypad for keyless entry
- Beep feedback indicating success and failure of actions as well as low battery conditions
- Easy installation in standard door cutouts and direct replacement for standard travel trailer entrance locks from:
  - FIC / Wesco
  - Bauer
  - TriMark
- Support for two access codes—a factory default code and a customer code
- Interior safety release button for emergency exit
- Customer key access for alternative operation of the lock
- Can be keyed-alike to match other Pro Series locks

The lock is powered by a single Type 123 lithium battery and operates with a 4-digit code. Each lock has a factory default code that can be used at any time and cannot be erased; 1 additional customer code can be added.

**Important:** Before using the lock, record the default 4-digit code printed on a label affixed to the inside handle of the lock. The factory default code is needed for keyless entry before a customer code has been added and to program / reprogram the customer code.

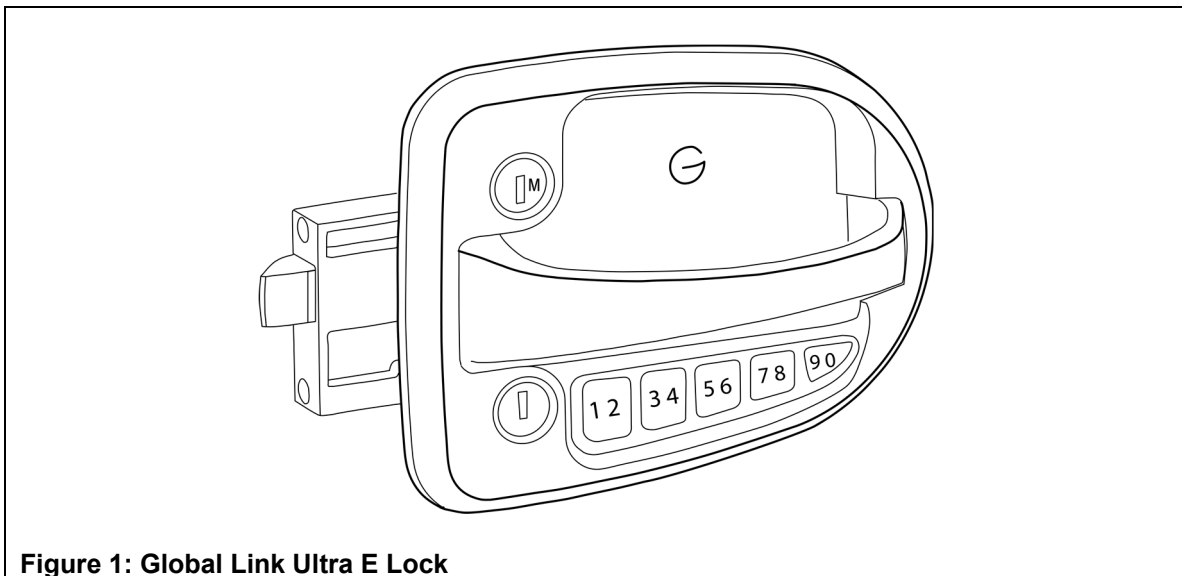

Figure 1: Global Link Ultra E Lock

 **WARNING:** Cancer and Reproductive Harm – [www.P65Warnings.ca.gov](http://www.P65Warnings.ca.gov).

## **Locking and Unlocking**

The lock supports both keyless and keyed operation.

**Important:** It is recommended to lock the deadbolt during transportation for added security.

### **Using the Keypad**

#### **To lock the door:**

1. Press any key to wake up the keypad.
2. Press and hold the 1-2 key and the 3-4 key at the same time. Two descending beeps indicate success.

#### **To unlock the door:**

1. Press any key to wake the keypad.
2. Enter the factory default code (printed on a label affixed to the inside handle of the lock) or the current customer code. Two ascending beeps indicate success.

**Notes:** If 4 quick beeps sound, the code was incorrect; enter the correct code. If an incorrect code is entered twice, the keypad goes to sleep; wake the keypad to try again.

### **Using the Deadbolt Lever**

Use the red deadbolt lever to lock and unlock the door from the inside (as shown).

**Note:** For exit in the event the deadbolt lever fails, slide and hold the safety release button and open the door.

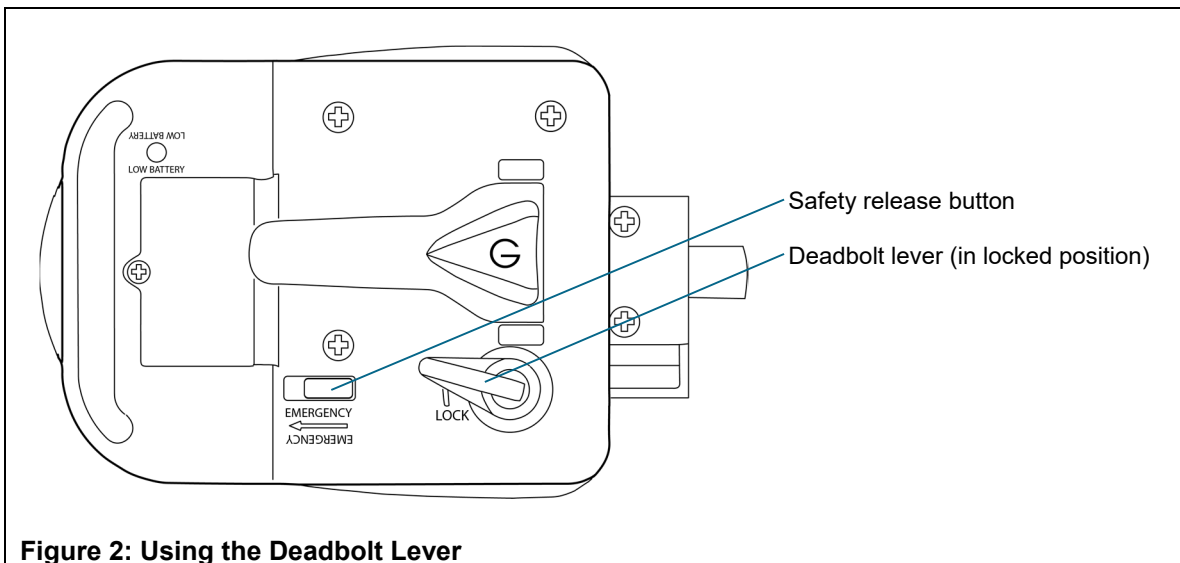

**Figure 2: Using the Deadbolt Lever**

## Programming the Customer Code

A 4-digit code is required for keyless locking and unlocking from the outside of the door. The lock supports 2 codes—the factory default code and a customer code.

The factory default 4-digit code is preprogrammed and cannot be erased. This code can be found on a label affixed to the inside handle of the lock.

### Adding or changing the customer code

1. Press and hold the 9-0 key for 3 seconds until the lock beeps twice.
2. Enter the factory default code or the current user code. Two beeps indicate a correct code.  
**Note:** Each key represents two numbers. For example, to enter “2”, press the 1-2 key.
3. Enter the new code. The three varied beeps indicate a new code was entered.
4. Enter the new code again to confirm. (If you enter an incorrect digit, press and hold the 9-0 key and re-enter the code.) Three varied beeps indicate success.

**Note:** If 4 quick beeps sound, the codes did not match; start again.

## Beeps Summary

The lock sounds a series beeps to signal success or failure of an action. The keypad flashes each time the lock sounds a beep.

Beeps	Meaning
1 short beep	Keypress
2 beeps	Factory default code or user code entered
2 beeps (after 3 seconds)	Programming mode entered
2 ascending beeps	Unlocking successful
2 descending beeps	Locking successful
3 varied beeps	New code entered
3 varied beeps	Programming successful
4 quick beeps	Incorrect code entered
4 quick, descending beeps	Low battery

## Changing the Battery

The lock is powered by a single Type 123 lithium battery and indicates low battery power by:

- a flashing LED on the inside of the lock when the keypad is activated
- 4 quick, descending beeps and a flashing keypad light any time a key is pressed

If the batteries die with the deadbolt in the locked position, the deadbolt remains locked. The customer key can be used to unlock the door.

It is recommended that the battery be removed if the lock will be stored or will not be used for an extended period of time.

**Important:** Before installing the battery for a new lock, record the factory default code, which is printed on a label affixed to the inside handle of the lock. The factory default code is needed for keyless entry before a customer code has been added and to program / reprogram the customer code.

### To change the battery

1. Use a #2 Phillips screwdriver to loosen the captive battery compartment screw on the interior of the lock. Do not completely remove the screw.
2. Lift off the battery compartment cover.
3. Remove the old battery from the battery holder.

**Note:** Dispose of the old battery according to local regulations.

4. Insert a new battery in the correct orientation (shown on the battery holder).
5. Insert the battery door tabs in the slots on the battery compartment and swing the door closed. Tighten the screw to secure the battery door.

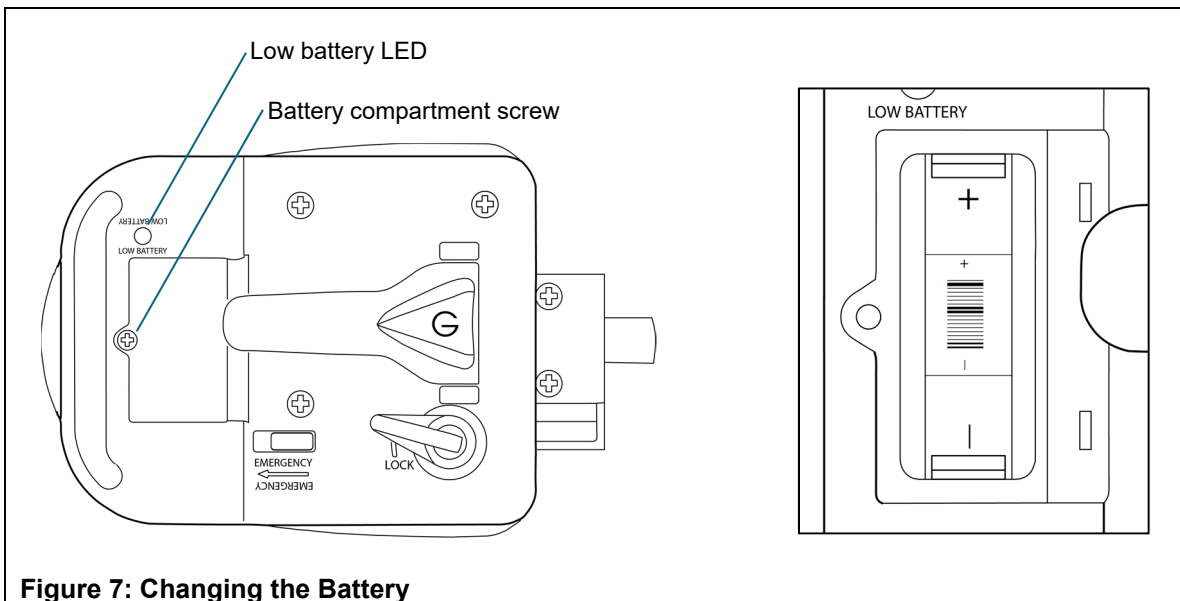

Figure 7: Changing the Battery

## ***Installing the Lock***

The Global Link Ultra E Lock fits:

- hole cutouts from 2 1/2" x 3 5/8" to 3" x 4"  
Recommended: 2 3/4" x 3 3/4"
- door thicknesses from 1 1/4" to 1 1/2" (most standard RV doors)

**Note:** Installation videos can be found at [cpgbrands.com](http://cpgbrands.com).

### **To install the lock**

1. Remove the existing lock.
2. Position the exterior lock assembly (with keypad) on the outside of the door, ensuring the plunger assembly is positioned at the edge of the door as shown.
3. Using the 2 #8-32 x 3/8" flat head screws provided, install the door edge cover on the edge of the door. Ensure the door edge cover is flush to the edge of the door.

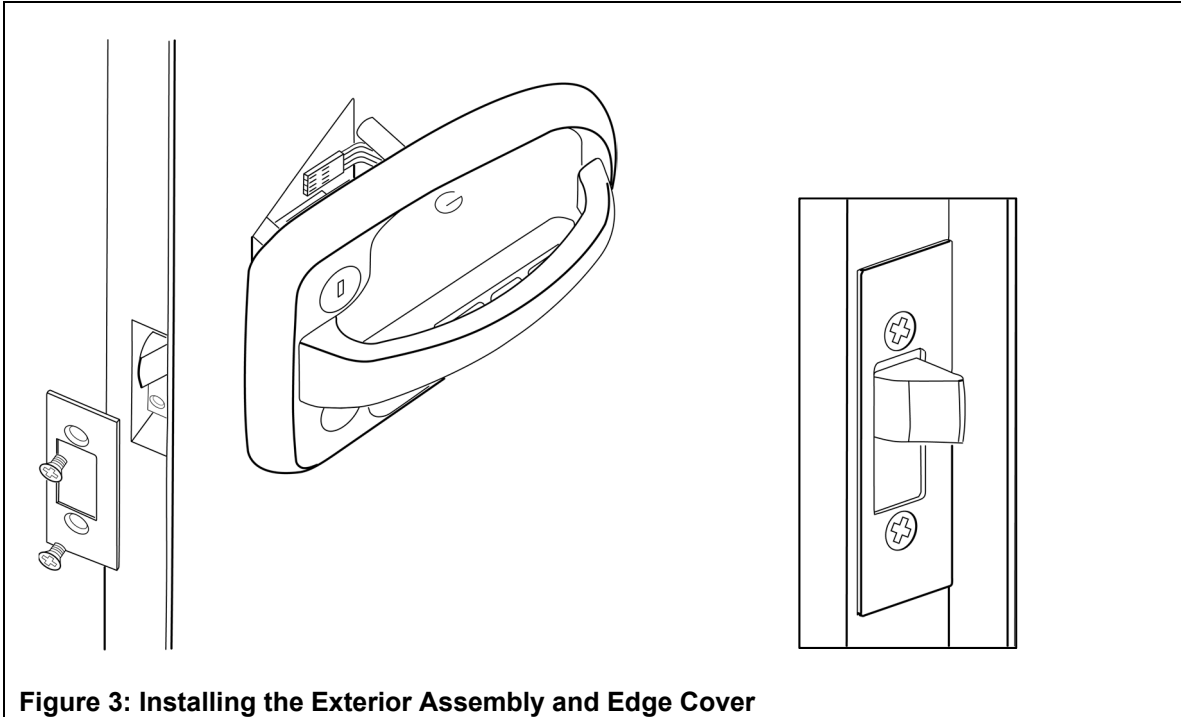

**Figure 3: Installing the Exterior Assembly and Edge Cover**

4. Connect the cable attached to the interior lock housing to the cable attached to the exterior lock housing. Refer to the figure and position the cable inside the door as shown to avoid pinching and binding.

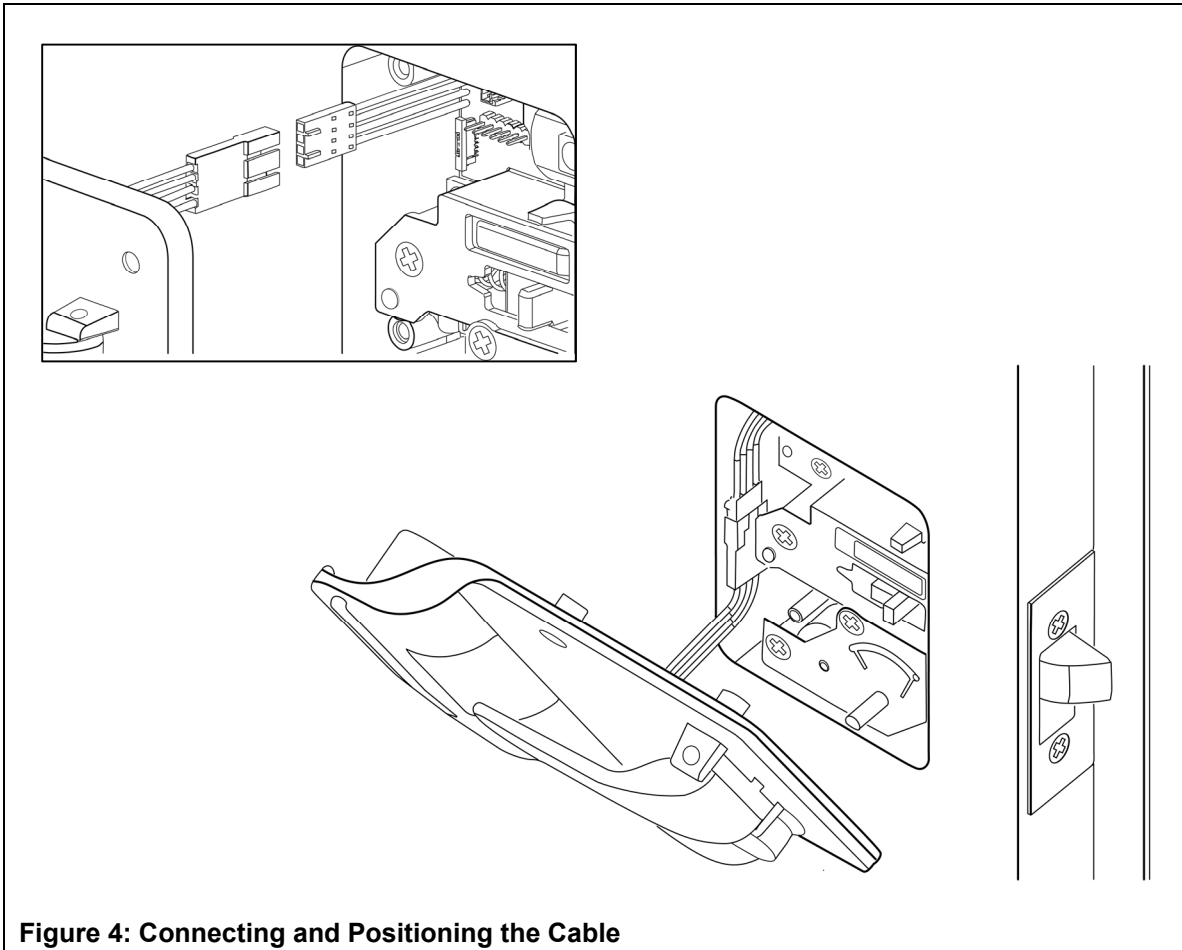

**Figure 4: Connecting and Positioning the Cable**

5. Refer to the figure and position the interior lock assembly on the door, ensuring:
  - The deadbolt post is inserted in the red deadbolt lever so that the lever operates the deadbolt.
  - The interior handle post is positioned on the door-edge side of the latch tab so that the handle operates the latch.
  - The 3 screw posts on the interior housing align with the 3 screw bosses on the exterior housing. *Do not overtighten the screws.*
6. Secure the lock housings with the 4 #8-32 x 7/8" oval head screws provided.
7. Ensure the handle operates the latch and the red deadbolt lever operates the deadbolt.

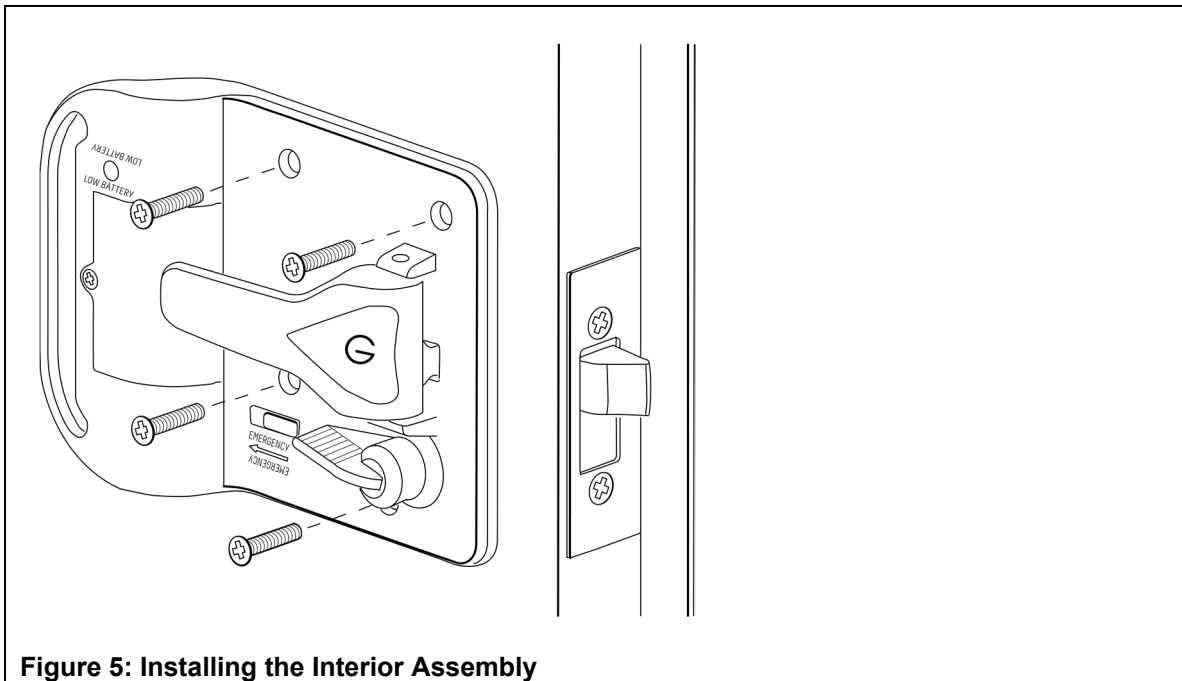

8. Check that the strike plate is properly aligned with the lock. If necessary, adjust alignment to ensure:
  - The lock functions properly. The plunger should extend fully into the strike plate when the door is locked.
  - The door opens and closes smoothly and seals completely when closed.

***Troubleshooting***

<b>Issue</b>	<b>Possible Causes</b>	<b>Solution</b>
Customer code does not lock or unlock the door	Code is incorrect  Key was not pressed to wake the keypad before entering the code  Customer code was erased	Confirm the correct code or use the factory default code.  Press any key to wake the keypad and then enter the 4-digit code.  Use the factory default code to reprogram the customer code.
Keypad does not respond to key presses	Battery has died or is installed improperly	Use the key to open the door and then replace the battery.
Red LED flashes	Battery is low	Replace the battery.
Lock sounds 4 quick, descending beeps and flashes keypad light when a key is pressed	Battery is low	Replace the battery.
Deadbolt does not latch	Plunger is not fully extended into the strike plate  Strike plate is misaligned, creating drag on the plunger  Lock is installed incorrectly  Obstruction in door is blocking the deadbolt  Obstruction is blocking the deadbolt lever	Open and close the door firmly to ensure the plunger extends fully into the strike plate.  Realign the strike plate.  Refer to the installation instructions and reinstall the lock.  Remove the lock, clear the obstruction in the door, and reinstall the lock.  Clear the obstruction blocking the deadbolt lever.
Door does not lock using the keypad	Battery is low or has died  Plunger is not fully extended into the strike plate  Strike plate is misaligned, creating drag on the plunger  Obstruction is blocking red deadbolt lever	Change the battery.  Open and close the door firmly to ensure the plunger extends fully into the strike plate.  Realign the strike plate.  Clear the obstruction blocking the deadbolt lever.
Battery cannot be removed	Battery fits tightly in the battery holder	Use a thin, blunt instrument to gently pry the battery from the holder.

***Limited Warranty***

For warranty information, visit [www.cpgbrands.com](http://www.cpgbrands.com).